

Panel High Bay

Lumen

130 lm/W

Lumen

160 lm/W

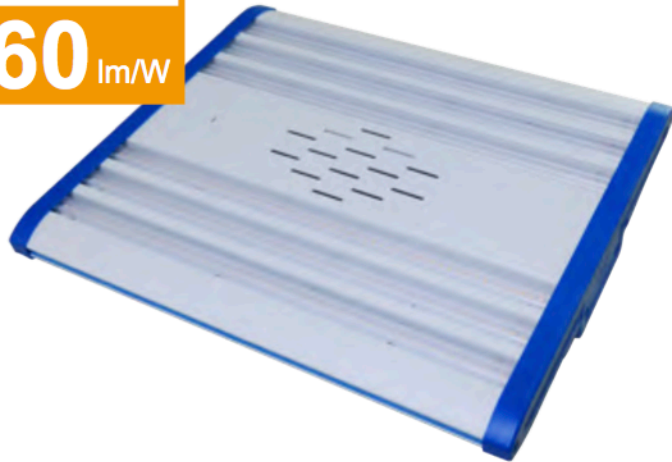

Features & Benefits:

- Isolated Longbright brand power supply
- Super bright LM80 LED 2835SMD, Ra>80
- Lumen output : 125-130lm/w
155-160lm/w
- Longbright brand isolated driver, PF>0.9, THD≤ 20 %
- AC120-277V / 347-480V, 0/1-10V dimmable
- High Quality PC Lens
- Non-flicker, protect your eyes
- 5-7 days fast delivery once confirmed
- UL cUL certifications
- Ideal replacement for traditional high bay with over 80% energy saving
- 5 Years warranty



Specifications

Technical Specification

Input Voltage: AC120-277V / 347-480V, 50Hz~60Hz

THD: $\leq 20\%$

PF: >0.90 Non-Flicker

Power Efficiency: $>90\%$

LED light source: high bright SMD2835

Color Temperature: 3000K, 4000K, 5000K

Color Rendering Index: CRI >80

Beam Angle: $60^\circ / 90^\circ / 120^\circ$

Material: PC + AL

Working Temperature: $-20^\circ\text{C} \sim +45^\circ\text{C}$

Storage Temperature: $-25^\circ\text{C} \sim +65^\circ\text{C}$

IP Grade : IP40

Working Life-span: 50,000H

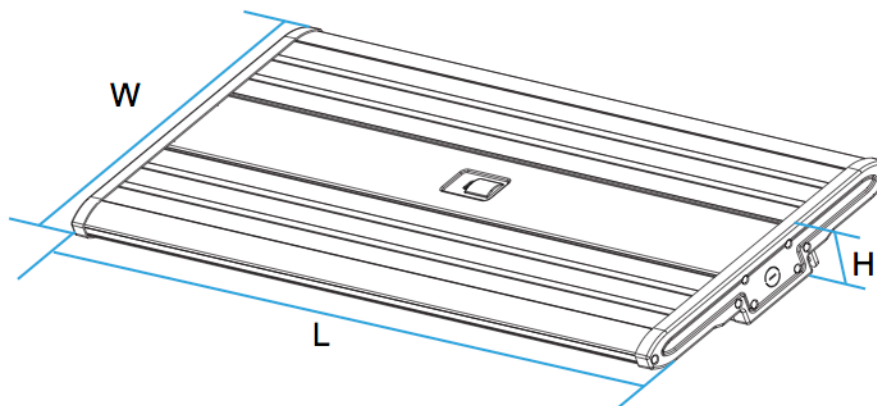

Model	SIZE(L*W*H)
PHB04-120	450*380*62mm
PHB06-200	600*380*62mm
PHB09-280	900*380*62mm
PHB12-400	1200*380*62mm

Parameters

Parameters

Model	Watt	Input Voltage	Lumens	Size	CCT	N.W
PHB04-120	120W	AC120-277V or AC347-480V	130lm/W or 160lm/W	450*380*62mm	3000K	5.0 kg/pc
PHB06-200	200W			600*380*62mm	4000K	6.5 kg/pc
PHB09-280	280W			900*380*62mm	5000K	9.0 kg/pc
PHB012-400	400W			1200*380*62mm	13.0 kg/pc	



Structure & Packaging

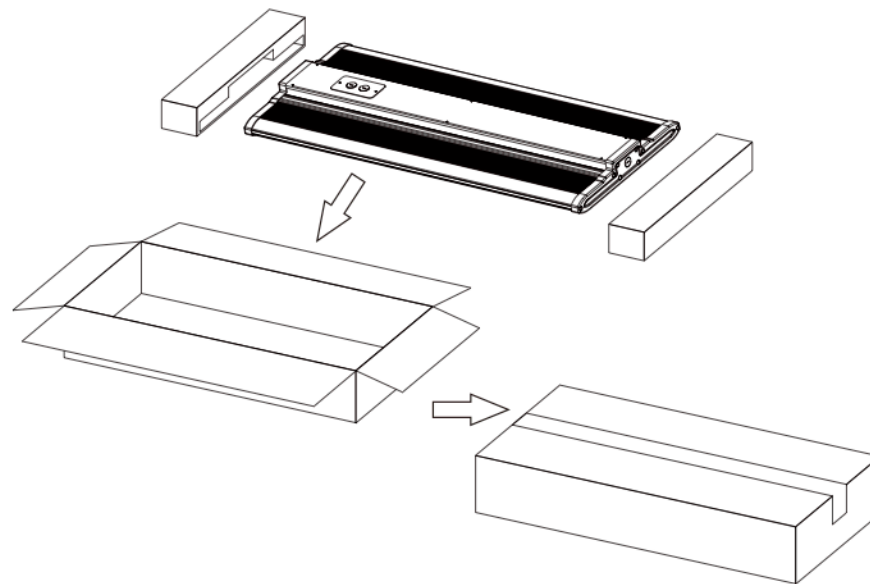
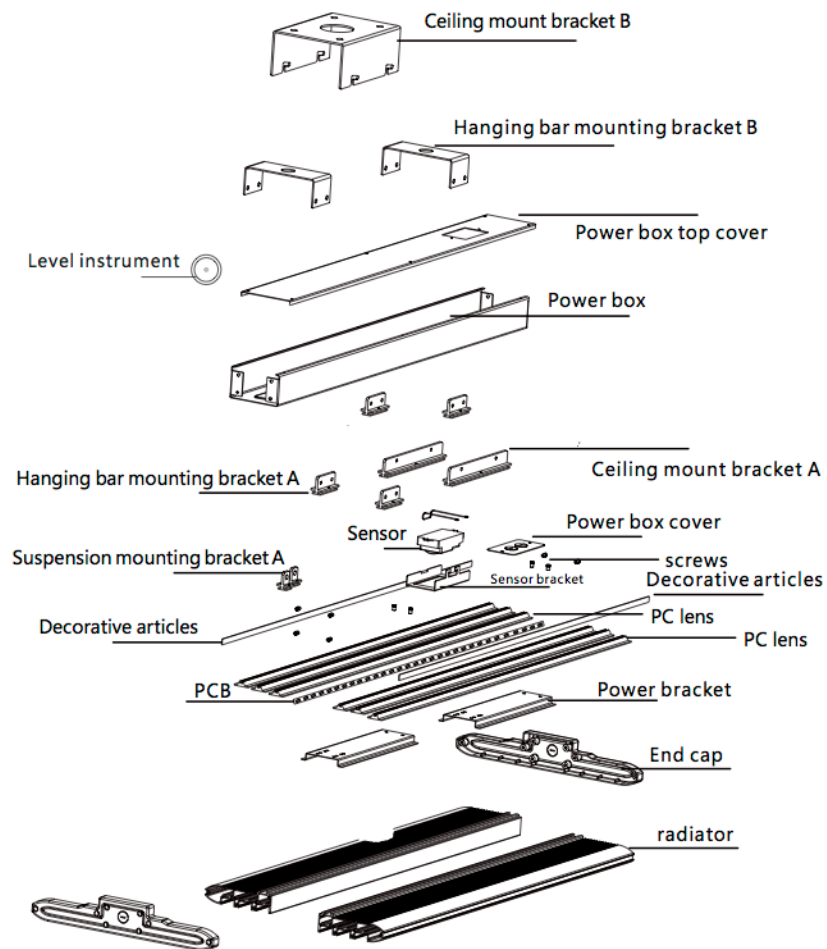

Item	N.W	G.W	CTN Size
120W	5.0 kg	6.2 kg	500x410x115mm 1pc/CTN
200W	6.5 kg	7.7 kg	650x410x115mm 1pc/CTN
280W	9.0 kg	10.3 kg	950x410x115mm 1pc/CTN
400W	13.0 kg	14.7 kg	1250x410x115mm 1pc/CTN

Optional Functions

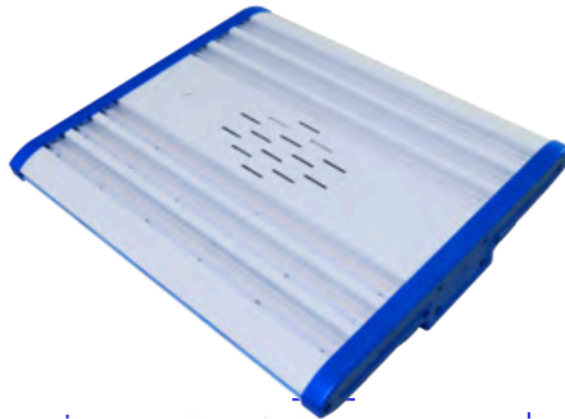

DM(Dimming function)



SN(Sensing function)



EP(Emergency function)

Contact Us



Tel : (845) 300-9399

E-mail : billn@rocklandled.com

Web : www.rocklandled.com



Add : 425 Western Highway, Tappan NY 10983